

Operating Instructions and Safety Precautions for the EHF Series Charger

Safety

Only a trained person should operate this equipment. The input and output voltages used with this equipment may be high enough to endanger life, so insulated, shrouded connectors must be fitted.

Please read this manual completely and convey instructions to all personnel concerned. Keep the manual in a safe and convenient place.

It is advisable to thoroughly read the information on battery safety supplied with the battery, prior to charging.

Towards the end of charge, lead acid batteries give off hydrogen gas, which is explosive if in sufficient concentration, therefore avoid flames and sparks. Appropriate measures must be taken to ensure adequate ventilation.

Incorrect use of a charger or maladjustment of its controls can damage a battery. The equipment has been factory set and does not require user adjustment.

This product has been designed, manufactured and certified to be in conformance with UL Standards. Testing has ensured that the battery and charger combination conform as a system for use in Light and Heavy Industrial environments for each respective product variant. The following notes are for the guidance of the person installing and using the product.

The charger must be isolated from the input supply and the battery, before any of the panels are removed. It is strongly recommended that a Safety Warning Notice is placed at the input supply isolator, to warn against inadvertent reconnection of the mains supply and the isolator is locked in the off position.

DANGER - Risk of electric shock. Do not touch un-insulated portion of output connector or un-insulated battery terminal.

Installation

Installation must only be carried out by suitably qualified personnel and in accordance with current local and national wiring regulations.

The unit should be positioned using lifting equipment, placed under the base.

Battery leads should not be altered without prior consultation with service personnel.

The charger should be sited in a cool, dry, well-ventilated location away from corrosive fumes and humid atmospheres. Ambient temperature range must be maintained between 32°F - 95°F.

The charger must have a minimum clearance overhead of eight inches (8"), ensuring ventilation is not obstructed at the rear intake and the front exhaust vents.

The charger is for inside use only.

Before installation, check that:

- The charger has not sustained any transit damage.
- The rating is suitable for the intended input supply and 'lead acid' battery to be charged.
- The connector polarity is correct and matches the polarity of the battery connector.

Input supply

A hand operated lockable isolator should be used in the installation, to enable the charger to be disconnected from the supply, for maintenance or repair work. The charger does not exhibit high in-rush current, therefore type B or C circuit breakers can be used.

CAUTION - To reduce the risk of fire, use only on circuits provided with branch circuit protection consistent with the current indicated on the rating label and in accordance with the National Electrical Code, ANSI/NFPA 70 or equivalent.

The circuit breakers rating should be based on the chargers maximum input current, as stated on the rating label.

Careful consideration must be taken when connecting this charger to a generator. The generator must be capable of at least four times the input power requirements of the charger, failure to do so can result in damage to the charger. The generator should have load step immunity to prevent undershoot and overshoot with typical loads. Typically the generator control bandwidth should be less than 7Hz with good gain and phase margins.

Display and Control

Overview

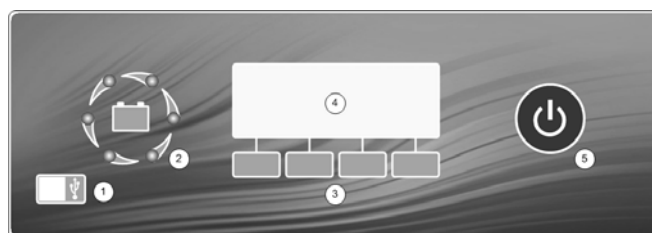







1. Communications Port
2. High Visibility - Charge Status Indicator
3. Soft-keys (The function of the button will be displayed on the LCD Display)
4. LCD Display
5. Pause Button

Charge Status Indicator

INDICATION	CHARGE STATUS INDICATION	MODE
1	Cycling red	Bulk charge / battery recovery mode
2	Cycling yellow	Second stage / watering
3	All green	Charge complete
4	Green with cycling red	Auto-balance pulse / refresh pulse / equalising / cool down
5	All flashing red	Critical fault
6	All off	Standby / pause / inhibit
7	Left hand indicator red	Power save mode

LCD Symbols

-  *Watering system (Shown when enabled, flashing during operation)
-  Communications port (Shown when active)
-  Equalise (Shown when enabled, flashing during operation)
-  Automatic Equalise (Shown when enabled, flashing during operation)
-  Warning (Shown when a warning is active)
-  Battery Recovery Mode (Shown when enabled, flashing during operation)
-  *Air system enabled (Shown when enabled, flashing during operation)

* Optional extra

Operation

Before connecting the battery, check that the battery voltage corresponds to the voltage indicated inside the battery symbol on the LCD Display. The charger should be permanently connected to the mains supply.

Standby

With the input supply connected and no battery, the charger will enter the standby mode. During this mode the charge status indicator will show indication 6 and the LCD display will show the following:

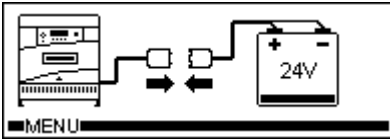

As a power saving feature the LCD backlight will be switched off after 1 minute of inactivity, the backlight can be turned back on by briefly pressing any of the buttons. During this time the charge status indicator will show indication 7.

Charging

When a battery is connected to the charger, charge will start automatically. The charge status indicator will show indication 1 or indication 2 (The speed of the rotation indicates the state of charge of the battery, with fast cycling indicating a low charge state) and the LCD Display will show the following:

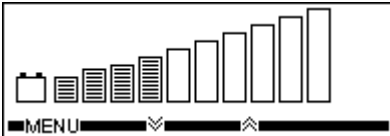

The bar graph display gives the user an indication of the batteries present state of charge.

During charge, the user can scroll through the following charge information, by pressing the ∇ or \blacktriangle keys.

- VPC Voltage per cell
- Ah Total Ampere hours delivered to the battery
- Amps The present output current
- Stage The present charge stage
- Charge Time The total charge time
- Rest Time Time elapsed since charge completed
- Warnings Displays any warnings - *Only shown when applicable*

Charge Complete

When charge is complete the charge status indicator will show indication 3 and the LCD Display will show the following:

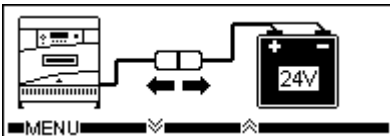

If the Auto Balance feature is enabled the battery should be left connected to the charger until required; under these conditions the battery will receive periods of refreshing charge to maintain it in the fully charged condition. During these periods, the charge status indicator will show indication 4.

Removing the battery

The battery can only be disconnected when charging current has stopped flowing. Therefore, the pause button must be pressed before disconnection. A second press of the pause key will clear the pause condition and continue charge (Disabled during the first 10 seconds of pause).

When the charger is paused the charge status indicator will show indication 6 and the LCD Display will show the following:



If the pause mode is entered but the battery is not removed within 10 minutes the charge will automatically continue.

Equalize Mode (Profile Dependant)

Periodically, batteries require additional charging to equalize all of

the cells to the same charge state, this should be performed after the standard charge has completed.

This mode can be enabled by pressing the = key during the charge cycle, a second press will clear this function. The equalize function can not be cleared once it has started and only one equalize is allowed per cycle.

In addition to enabling equalize manually, the equalize feature can be set to initiate automatically by configuring the automatic equalize feature in the programming mode. Automatic equalize may be set to occur every 0 to 250 cycles. Once set the A= symbol will be shown in the top right corner of the LCD Display.

Once enabled, the charger will perform the equalize function after the standard charge has been completed.

Battery Recover Mode

If a battery is connected to the charger that is below the normal operating voltage an incorrect battery fault (F07) will be displayed. However if the battery voltage is between 1 and 1.5VPC, battery recover mode is available. This mode employs a special charging technique to recover batteries that have been left unused for a long time or have been over discharged.

This mode can be enabled by pressing the BRM key when the fault is displayed. Battery recover mode will then start; once the battery voltage has been recovered to a normal level a standard charge will be performed.

Cool Down Mode (Profile Dependant)

Cool down mode is activated after the charge has completed and allows the battery time to 'cool down' before its next use. During this time the battery should remain connected to the charger, but can be removed if required.

Delayed Start

Note: This function is only available if the network function is OFF and can only be set without a battery connected.

The delayed start function will delay the start of charge for a set time up to 48 hours in 15 minute increments. The timer begins count down upon connection to a battery.

During the delay period the charge status indicator will show indication 6 and the LCD Display will show the following:

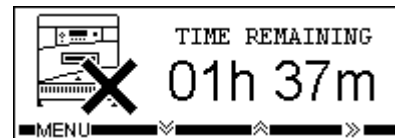

Once the time period has elapsed, charge will start as normal. This can be overridden by pressing the >> button, for this cycle only.

User menu

A user menu can be accessed by pressing the MENU key, the following options can then be scrolled through by pressing the ∇ or \blacktriangle keys and then activated by pressing the SELECT key:

Charger History

	Cycle Data	Total Charge Ah
	Cycle Graphs	Total Charge Time
	Total Initiations	
	Total Terminations	

Charger Information

	Charger Type	Software Version
	Module Part Number	Network ID
	Module Temperature	Network Speed
	Serial Number	Date Code
	Auto Equalisation	Watering System

*Battery History



Install Date	<50% DOD
Inits	<80% DOD
Terms	>80% DOD
<20% DOD	

*Battery Information



Fleet ID	Voltage
Capacity	S/N
Tag ID	ML No
	Cell Type

Language



English	Dansk
Francais	Svenska
Nederlands	Espanol
Deutsch	

Charger options



Auto Balance	AGV
Onboard	Safety Disconnect
Stored Equalize	BattID

Settings



Set LCD Contrast
Reset Charger
Override / Enable Inhibit

The menu can be exited by pressing the **BACK** key.

* This menu item can only be selected if the charger has the BattID option fitted.

Faults / Warnings

If a critical fault occurs during charge the charge status indicator will show indication 5 and the LCD Display will show the fault code and description, for example:



Faults permanently stop charge until they are rectified.

If a warning occurs during charge the warning symbol  will be displayed on the LCD Display and the warning code and description can be accessed by scrolling through the charge information.

Warnings do not affect the charge procedure.

Fault Codes

F06	No output current
F07	* Incorrect battery
F09	* Bulk charge timeout
F10	* Gassing charge timeout
F12	Configuration error
F13	Thermistor fault
F17	* Auto balance timeout
F18	Battery disconnected
F19	Battery disconnected during cooldown
F21	Over current

Warning Codes

F01	* Over discharged battery
F02	* Deep discharged battery
F03	* Sulphated battery
F04	Charger overheating

F05	Mains Failed during charge
F23	Batt ID PCB error
F24	Batt ID Antenna error
F25	Batt ID Tag read error
F26	Batt ID not programmed
F27	** Slave 1 incorrect correct current
F28	** Slave 2 incorrect correct current
F29	** Slave 3 incorrect correct current
F30	** Slave 1 temperature fault
F31	** Slave 2 temperature fault
F32	** Slave 3 temperature fault

* = These faults are usually associated with the battery, check battery condition.

** = Only applicable on models with dual power modules

Repair

Only suitably qualified personnel should perform repair work on this equipment.

Use of genuine factory sourced replacement parts is necessary to ensure UL marking is not invalidated.

Contact your local maintenance facility for assistance or replacement parts. Always be prepared with the charger type and serial number prior to placing a call for assistance.

Maintenance

Before carrying out maintenance, isolate the mains supply and disconnect the battery.

Only suitably qualified personnel should perform maintenance work on this equipment.

The charger will require little maintenance, but the following schedule is recommended once a month:

- Check the condition of all cables, paying particular attention to the points where cables may be severely flexed, i.e. at the entry to charger cabinet, charging plugs and sockets.
- Check condition of charging plugs and sockets for wear and any evidence of overheating, which could ultimately lead to charger malfunction.
- Check that ventilation is not obstructed.
- Ensure that all safety covers and panels are correctly in place.

**SALES – SERVICE
RECYCLING
1-888-563-6300
TOLL FREE**

www.gnb.com



A Division of Exide Technologies

EHF - 1PH - Installation Wiring

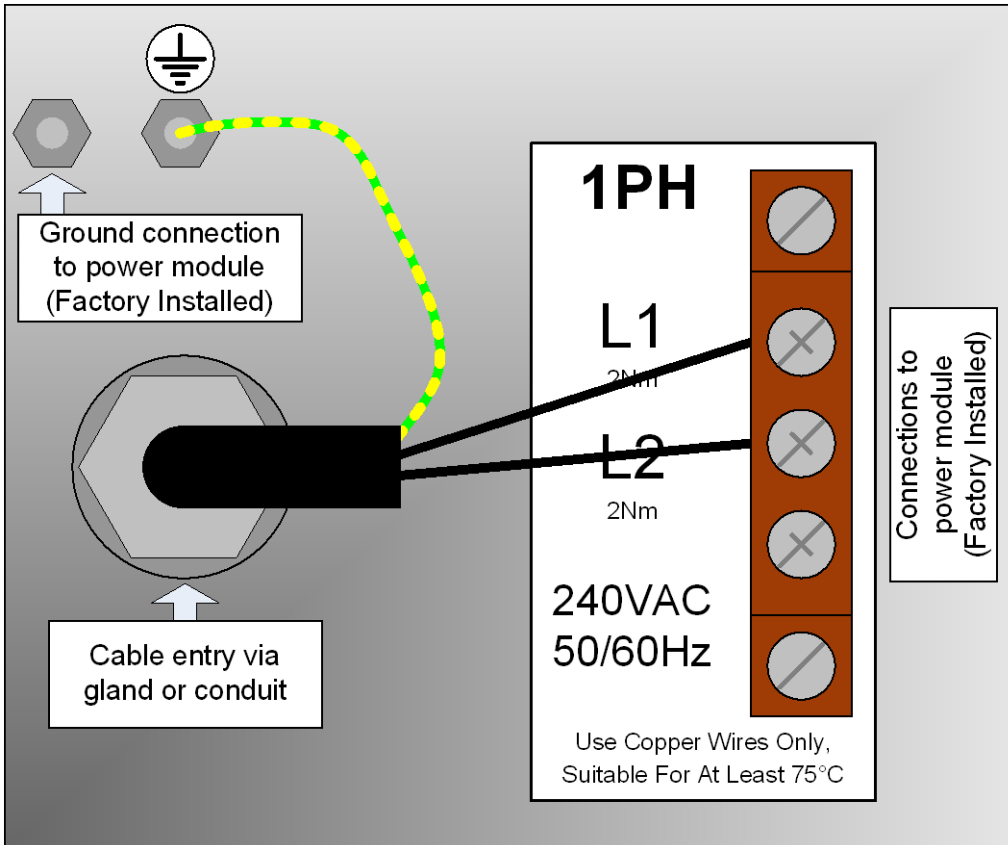

EHF - 3PH - Installation Wiring

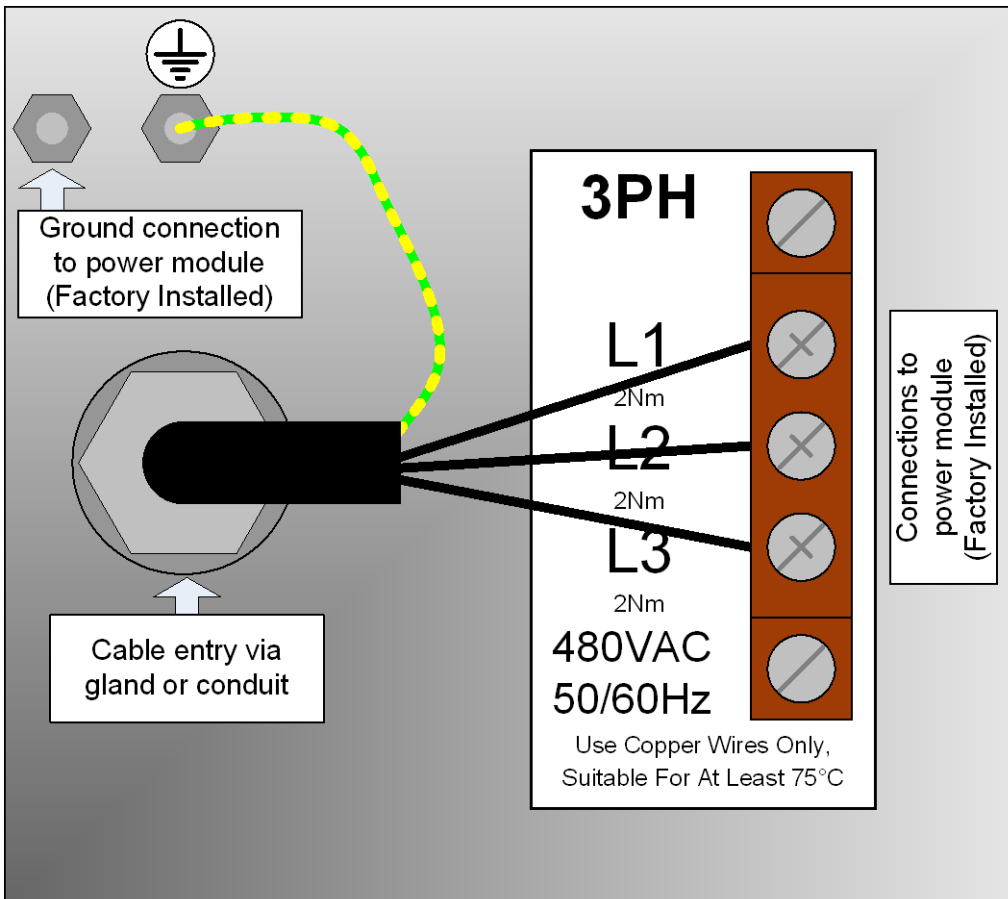

EHP - 1PH - Installation Wiring

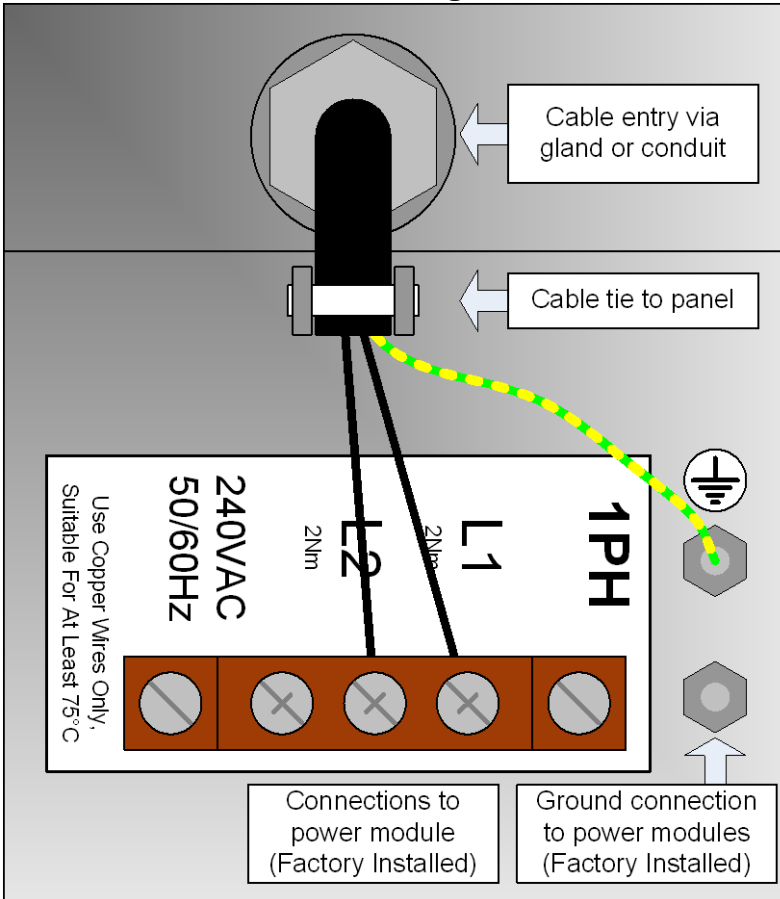

EHP - 3PH - Installation Wiring

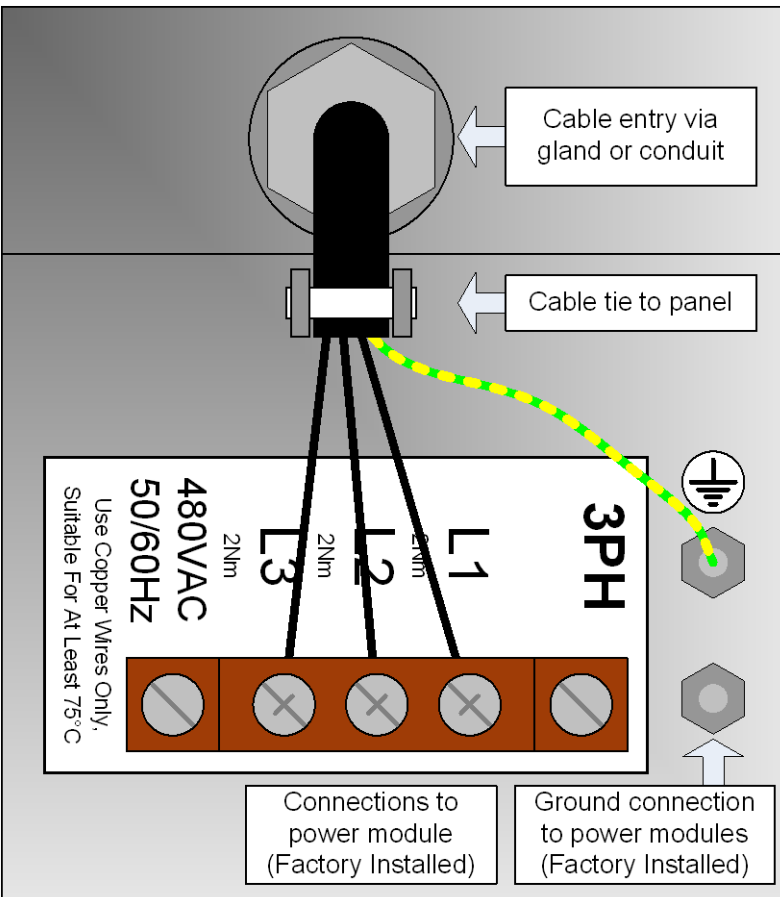

EMC - 1PH - Installation Wiring

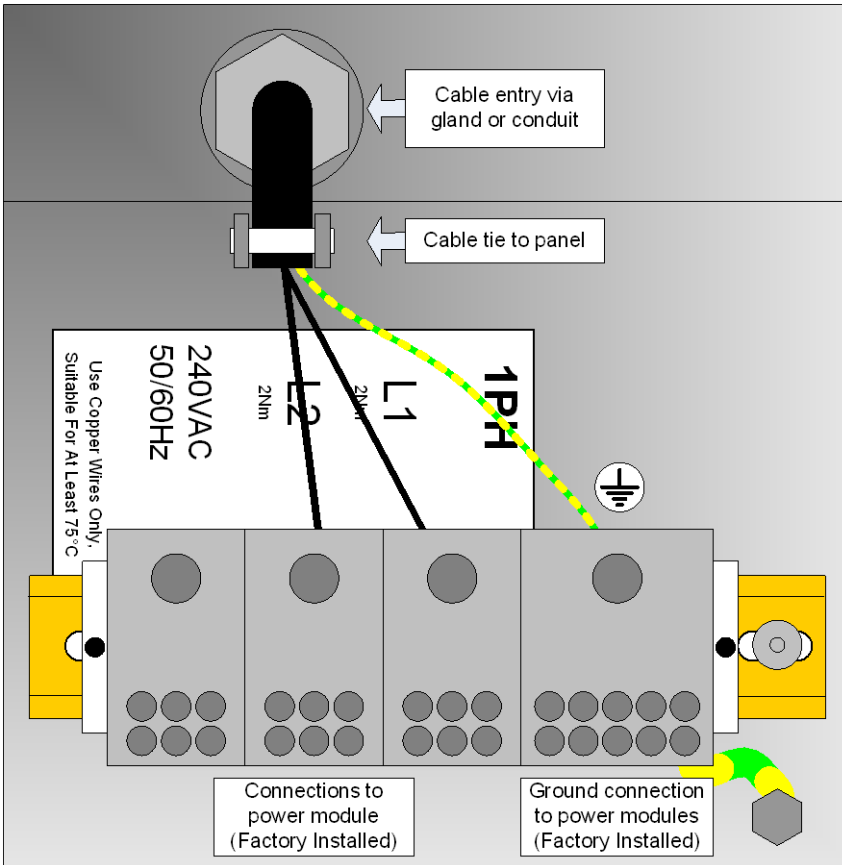

EMC - 3PH - Installation Wiring

